

Double glazed security sightglasses similar to DIN 28121

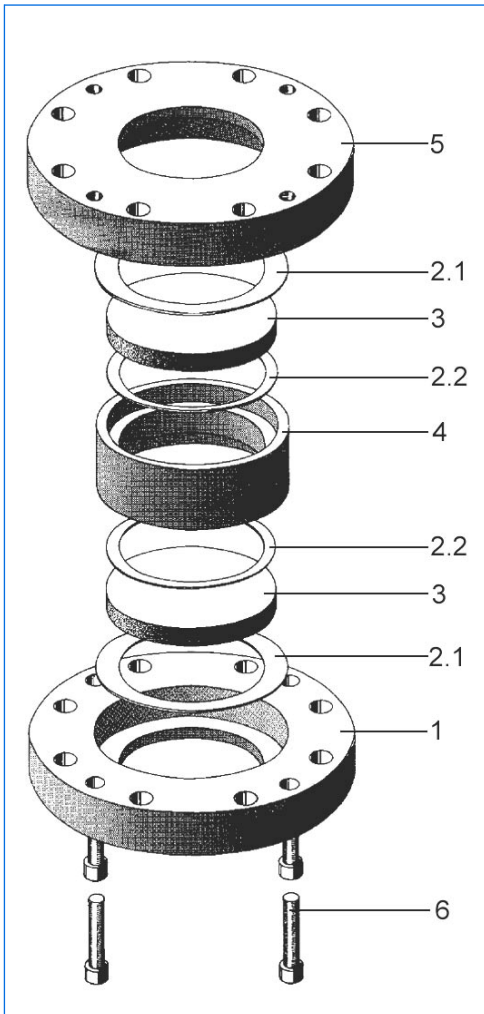

Double glazed safety sightglass similar to DIN 28121, DN 125, PN 10



For use with nominal pressure of PN 10 (higher pressures on demand)

Application:

For cases where the possible destruction of a single sightglass would present a considerable safety risk.

The sightglasses contain two independent glass discs built into an intermediate support ring. The damage of one disc doesn't affect the guaranteed security of the unit.

The preassembled units are to be screwed onto existing pre-welded, base or other flanges.

Dimensions to DIN 28121, except the height.

Maximum allowed temperatures:

280 °C with glass discs in borosilicate to DIN 7080

150 °C with glass discs in sodium silicate to DIN 8902

The above indicated temperatures may change depending on the quality of the gaskets

Nominal diameters:

DN 50 - DN 200 (free view from 65 mm to 175 mm)

Construction and materials:

Pos.:	Part:	Material:
1	Base flange	Boilerplate, stainless steels, Titanium, Hastelloy etc.
2.1 / 2.2	Gaskets	KLINGERSil C 4400, Silicone, PTFE etc.
3	Sightglass discs	Sodium silicate to DIN 8902 Borosilicate to DIN 7080
4	Intermediate support ring	Boilerplate, stainless steels, Titanium, Hastelloy etc.
5	Cover flange	Boilerplate, stainless steels, Titanium, Hastelloy etc.
6	Tightening bolts	8.8, A2, A4

Option:

Also available as **heated** version to prevent condensation or deposits on the glass discs.

Electrical data:

Supply voltage: 24 V (AC or DC)

Nominal rating: 50 / 75 / 100 W (not regulated)

Further applications:

- **Spoiling** with cooling liquids e.g. to prevent non allowed elevated glass temperatures
- **Leak control**, e.g. by spoiling with inert gases and concentration monitoring or measuring pressure differences

Possible combinations:

Above sightglasses may be combined with our sightglass light fittings of the series CHEMLUX®, EdelLUX®, fibroLUX®, miniLUX® or metaLUX®. With integrated heating element, the use is restricted to safe area applications.

Certificates:

To be supplied against extra charge to DIN EN 10204.

Nominal diameter (DN)	Viewing diameter d1	Glass discs		Base flange and cover flange			Gaskets			Tightening bolts **		
		d3	s	D	k	h3	d10	d1	d4 *	Number	Size	d9
50	65	80	10	165	125	77	97	50	82	4	M16	18
80	80	100	15	200	160	81	127	80	102	8	M16	18
100	100	125	15	220	180	85	152	100	127	8	M16	18
125	125	150	20	250	210	102	177	125	152	8	M16	18
150	150	175	20	285	240	102	202	150	177	8	M20	22
200	175	200	20	340	295	102	227	175	202	8	M20	22

* The dimension d4 (not shown) is the dimension d3 + 2 mm each. The dimension d4 is the outside diameter of the inner gaskets.

** Not contained in our delivery

Construction:

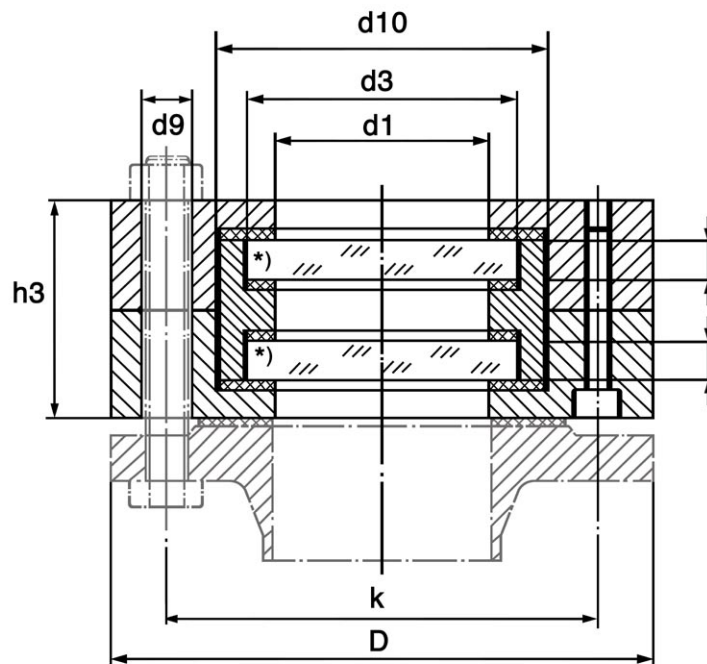

Mounting:

By using the fixation bolts of which the number and size are indicated in the above table, the complete, premounted, tightened and sealed unit is fixed onto a welding flange, pad or similar. The heating element (optional) has to be connected via a temperature regulation device to 24 V AC or DC.

All dimensions in mm. Subject to changes without preliminary notice.



MAX MÜLLER AG

PROCESS ILLUMINATION AND VISUAL OBSERVATION SYSTEMS

Hagmattstrasse 19 • CH - 4123 Allschwil / Switzerland

Telephone +41 61 487 92 92 • Telefax +41 61 487 92 99

www.maxmuellerag.com E-Mail: blt@maxmuellerag.com