

Double glazed sightglasses similar to DIN 28120, with or without heating element



Double glazed sightglass similar to DIN 28120, DN 150, PN 16, with integrated heating element, 24 V, 50 W

For use with nominal pressures of PN 6 / PN 10 / PN 16

Application:

For cases where undesired condensation and product deposits on the inner side of the glass discs have to be avoided.

The sightglasses contain two independent glass discs built into an intermediate ring. The heating element is built into the intermediate ring. The sightglasses are delivered to be welded into or onto a vessel wall. Dimensions to DIN 28120, except the height.

Maximum allowed temperatures:

280 °C with glass discs in borosilicate to DIN 7080

150 °C with glass discs in sodium silicate to DIN 8902

Above indicated temperatures may change depending on the quality of the gaskets.

Nominal diameters:

DN 50 - DN 200 (free view from 80 mm to 225 mm)

Materials:

Base flange: Boilerplate, stainless steels, Titanium, Hastelloy etc.

Gaskets: KLINGERSil C 4400, Silicone, PTFE etc.

Sightglass discs: Sodium silicate to DIN 8902

Borosilicate to DIN 7080

Intermediate ring: Boilerplate, stainless steels, Titanium, Hastelloy etc.

Cover flange: Boilerplate, stainless steels, Titanium, Hastelloy etc.

Tightening bolts: 8.8, A2, A4

Electrical data:

Supply voltage: 24 V (AC or DC)

Nominal rating: 50 / 75 / 100 W (not regulated)

Further applications:

- **Spoiling** with cooling liquids e.g. to prevent non allowed elevated glass temperatures
- **Leak control**, e.g. by spoiling with inert gases and concentration monitoring or measuring pressure differences

Options:

- Also available without heating element
- Security version

Possible combinations:

Above sightglasses may be combined with our sightglass light fittings of the series CHEMLUX®, EdelLUX®, fibroLUX®, miniLUX® or metaLUX®. With integrated heating element, the use is restricted to safe area applications.

Certificates:

To be supplied against extra charge to DIN EN 10204.

Nominal Diameter (DN)	Pressure rating (PN)	Viewing Diameter d1	Glass discs		Base flange and cover flange				Bolts or studs / nuts					
			d4	s	D	k	h1	h2	L	Number	Size	Tightening torque (Nm)		
50	6	80	100	10	165	125	16	30	65	4	M16	28		
	10			15					65				32	
	16			15					75				32	
80	6	100	125	15	200	160	18	30	75	4	M16	20		
	10			15					75				8	20
	16			20					95				8	23
100	6	125	150	15	220	180	18	30	75	8	M16	26		
	10			20					90				8	30
	16			25					100				30	
125	6	150	175	20	250	210	18	30	85	8	M16	32		
	10			20					90				8	34
	16			25					100				8	34
150	6	175	200	20	285	240	18	36	85	8	M20	47		
	10			25					110				8	54
	16			30					120				8	54
200	6	225	250	25	340	295	20	36	100	8	M20	63		
	10			30					125				8	63

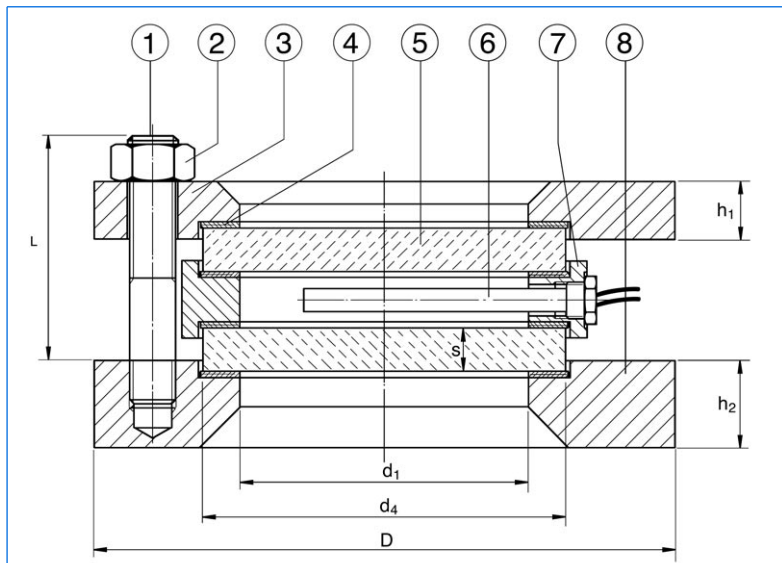

Assembly and construction

- | | |
|---|-------------------|
| 1 | Bolts or studs |
| 2 | Nuts |
| 3 | Cover flange |
| 4 | Gaskets |
| 5 | Glass discs |
| 6 | Heating element |
| 7 | Intermediate ring |
| 8 | Base flange |

Mounting:

After having correctly welded the base flange ③ onto or into the vessel wall, the gaskets ④, the glass discs ⑤, the intermediate ring ⑦ as well as the cover flange ③ are positioned one after the other and then the nuts ② progressively tightened against the bolts or nuts ①. The above indicated tightening torque values (in Nm) have to be strictly respected. The nuts have to be tightened over cross. Additional information may be taken from the DIN specification 28120. The heating element ⑥ (50, 75 or 100 W) has to be screwed into the intermediate ring ⑦ and to be connected via a temperature regulation device to 24 V AC or DC supply.

All dimensions in mm. Subject to changes without preliminary notice.

